

RLE

Intelligent LED High-Bay Luminaire

Date: _____

Quantity: _____

Company: _____

Project: _____



The **RLE** Intelligent LED High-Bay Luminaire enables advanced lighting controls for impressive energy savings, unlocks beyond lighting applications, and empowers users to more efficiently and affordably maintain a state-of-the-art facility for the lifetime of the luminaire.

The RLE incorporates the **LGT Port** paired with the interchangeable **LGT Port Sensing and Communications Modules**.

SiteWorx Application

- SiteWorx Tune



Key Features & Benefits

- Light output from 18,740 to 65,419 lumens and efficacy up to 156 lumens per watt
- Narrow and Wide standard optics with optional glass covers for added durability and chemical resistance¹
- Optional EN 50172 and UL924 compliant Emergency Battery Backup solution provides illumination during power outages and automated life-safety testing
- Unique rotatable light bars and direct/indirect lighting distribution options for uniform lighting across both ceilings and workspaces. Standard aircraft cable or fixed mounting options
- Enables SiteWorx[®] Tune application to optimize your lighting and reduce energy use
- Incorporates the LGT Port paired with the advanced LGT Sensing and Communications Module, providing a simple and easy upgrade path with its future-proof design. As new sensing and communication technologies are released, you can easily take advantage while you keep your intelligent LED luminaires in place

LGT Sensing and Communications Module Specifications

PIR-BLE MODULE



Luminaire Insights

- Allows monitoring of luminaire energy consumption, operational status, occupancy trends, faults, and enables unparalleled light output and control

Luminaire Control

- Provides On/Off and precise 0% to 100% luminaire dimming
- Fully enables SiteWorx Tune lighting control capabilities, including task tuning, daylight harvesting, scheduled and automatic setback, and coordinated control

Sensing

- Integrated Passive Infrared (PIR) Sensor for occupancy detection. Occupancy information is collected and movement is detected within the sensor coverage area. The sensor can not detect or report any Personally Identifiable Information (PII)
- Integrated Photocell Sensor for daylight harvesting strategies to raise or lower light output based on available daylight

Network Communication

- SiteWorx Wireless Mesh Network IEEE 802.15.4 enabling communication with SiteWorx Software Smart Devices
- Includes AES-128 encryption to deliver secure, reliable communications that can easily coexist with other wireless networks within your facility
- Uses Bluetooth Low-Energy (BLE) to enable SiteWorx Area asset location capabilities in combination with AREA-TAG smart devices

Technology Platform

- Incorporates and extends the SiteWorx wireless mesh network

PIR MODULE



Luminaire Insights

- Allows monitoring of luminaire energy consumption, operational status, occupancy trends, faults, and enables unparalleled light output and control

Luminaire Control

- Provides On/Off and precise 0% to 100% luminaire dimming
- Fully enables SiteWorx Tune lighting control capabilities, including task tuning, daylight harvesting, scheduled and automatic setback, and coordinated control

Sensing

- Integrated Passive Infrared (PIR) Sensor for occupancy detection. Occupancy information is collected and movement is detected within the sensor coverage area. The sensor can not detect or report any Personally Identifiable Information (PII)
- Integrated Photocell Sensor for daylight harvesting strategies to raise or lower light output based on available daylight

Network Communication

- SiteWorx Wireless Mesh Network IEEE 802.15.4 enabling communication with SiteWorx Software Smart Devices
- Includes AES-128 encryption to deliver secure, reliable communications that can easily coexist with other wireless networks within your facility

Technology Platform

- Incorporates and extends the SiteWorx wireless mesh network

Luminaire Specifications

PERFORMANCE

Unified Glare Rating³

- < 10

Power Factor

- 0.9 minimum

Surge Protection

- Supplemental surge to 4 kV line-line, 4 kV line-earth

Wiring

- Direct wiring with PG-7 (0.5 inch) trade-size knockout

ENVIRONMENTAL

Operating Temperature⁴

- Luminaire
 - 40° to 65°C (-40° to 149°F)
- Luminaire with BBDRLE battery backup
 - 0° to 50°C (32° to 122°F) — UL
 - 0° to 30°C (32° to 86°F) — CE (RLE-D1/H1)
 - 0° to 25°C (32° to 77°F) — CE (RLE-P1)

Maximum Storage Temperature

- 65°C (149°F)

Operating Humidity

- 0% to 95%, non-condensing

Photobiological Safety

- RGI per IEC TR 62778

PHYSICAL

Luminaire Frame and Hardware

- Steel, powder coated
- Stainless Steel, powder coated

Impact Rating

- IK10

Optic Material

- Optical grade PC
- Optical grade glass (optional)

Optic Options

- Narrow
- Wide
- Narrow Glass
- Wide Glass

Mounting Options

- Aircraft Cable
- Fixed Mount

WARRANTY

- 10-Year Limited

CERTIFICATIONS & SAFETY

Approbation

- ETL, ETL-NOM, CE, UKCA, RCM, FCC Part 15 Class B, RoHS, CISPR 15, Design Lights Consortium DLC Standard

Environmental Suitability

- Indoor Use Only, IP66⁵



To identify the specific RLE luminaire model DLC Standard listing, visit qpl.designlights.org/

RLE-D1 ST/HV

Specifications

PERFORMANCE

Color Temperature⁶
5,000 K

Color Temperature⁶
4,000 K

Lumen Output (nominal)⁷

- 21,570 lm Standard Voltage (ST)
- 21,525 lm High Voltage (HV)

Lumen Output (nominal)⁷

- 18,740 lm Standard Voltage (ST)
- 18,829 lm High Voltage (HV)

Power Consumption (nominal)

- 145 W (ST)
- 142 W (HV)

Power Consumption (nominal)

- 144 W (ST)
- 141 W (HV)

Efficacy⁸

- 149 lm/W (ST)
- 151 lm/W (HV)

Efficacy⁸

- 130 lm/W (ST)
- 133 lm/W (HV)

CRI

- 70 minimum, 72 typical

CRI

- 80 minimum, 82 typical

Input Voltage⁹

- 120 to 277 VAC, 50/60 Hz (ST)
- 347 to 480 VAC, 50/60 Hz (HV)

Input Voltage⁹

- 120 to 277 VAC, 50/60 Hz (ST)
- 347 to 480 VAC, 50/60 Hz (HV)

PHYSICAL

Dimensions (H x W x D)

- 52 x 522 x 771 mm (2.2 x 20.5 x 30.4 inches)

Weight

- 5.9 kg (13 lbs)

LUMEN MAINTENANCE & DRIVER LIFETIME^{10,11}

	25°C	50°C
L₉₀ (12k)	> 300,000	> 300,000
L₈₀ (12k)	> 300,000	> 300,000
L₇₀ (12k)	> 300,000	> 300,000
Driver Lifetime	120,000	50,000

Dimensions

Luminaire

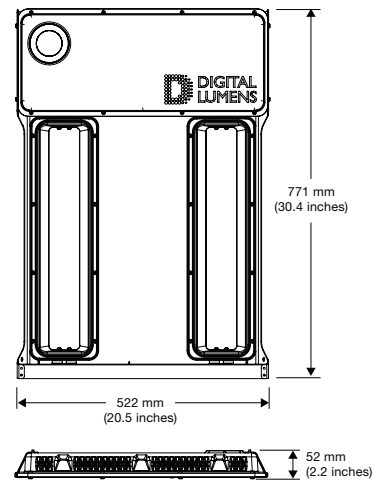

Fixed Mount Bracket

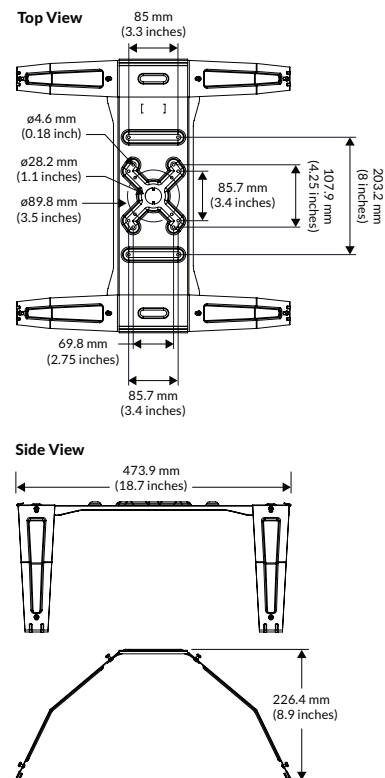

RLE-H1 ST/HV

Specifications

PERFORMANCE

Color Temperature⁶
5,000 K

Color Temperature⁶
4,000 K

Lumen Output (nominal)⁷

- 32,219 lm
Standard Voltage (ST)
- 32,040 lm
High Voltage (HV)

Lumen Output (nominal)⁷

- 28,360 lm
Standard Voltage (ST)
- 28,745 lm
High Voltage (HV)

Power Consumption (nominal)

- 214 W (ST)
- 210 W (HV)

Power Consumption (nominal)

- 212 W (ST)
- 209 W (HV)

Efficacy⁸

- 150 lm/W (ST)
- 152 lm/W (HV)

Efficacy⁸

- 134 lm/W (ST)
- 138 lm/W (HV)

CRI

- 70 minimum, 72 typical

CRI

- 80 minimum, 82 typical

Input Voltage⁹

- 120 to 277 VAC,
50/60 Hz (ST)
- 347 to 480 VAC,
50/60 Hz (HV)

Input Voltage⁹

- 120 to 277 VAC,
50/60 Hz (ST)
- 347 to 480 VAC,
50/60 Hz (HV)

PHYSICAL

Dimensions (H x W x D)

- 52 x 522 x 771 mm (2.2 x 20.5 x 30.4 inches)

Weight

- 6.4 kg (14 lbs)

LUMEN MAINTENANCE & DRIVER LIFETIME^{10,11}

	25°C	50°C
L₉₀ (12k)	> 300,000	> 300,000
L₈₀ (12k)	> 300,000	> 300,000
L₇₀ (12k)	> 300,000	> 300,000
Driver Lifetime	120,000	55,000

Dimensions

Luminaire

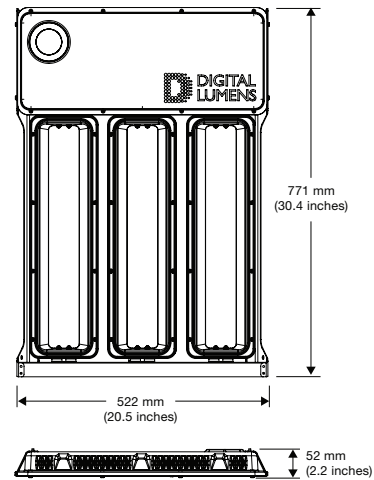

Fixed Mount Bracket

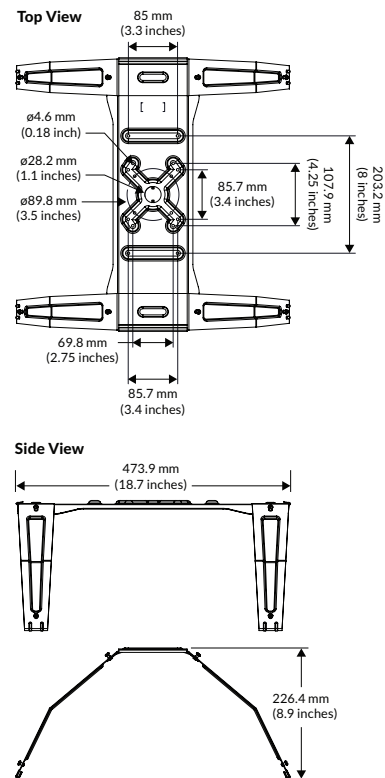

RLE-P1 ST/HV

Specifications

PERFORMANCE

Color Temperature⁶
5,000 K

Color Temperature⁶
4,000 K

Lumen Output (nominal)⁷

- 64,532 lm
Standard Voltage (ST)
- 65,419 lm
High Voltage (HV)

Lumen Output (nominal)⁷

- 56,563 lm
Standard Voltage (ST)
- 57,417 lm
High Voltage (HV)

Power Consumption (nominal)

- 428 W (ST)
- 419 W (HV)

Power Consumption (nominal)

- 429 W (ST)
- 415 W (HV)

Efficacy⁸

- 151 lm/W (ST)
- 156 lm/W (HV)

Efficacy⁸

- 132 lm/W (ST)
- 138 lm/W (HV)

CRI

- 70 minimum, 72 typical

CRI

- 80 minimum, 82 typical

Input Voltage⁹

- 120 to 277 VAC,
50/60 Hz (ST)
- 347 to 480 VAC,
50/60 Hz (HV)

Input Voltage⁹

- 120 to 277 VAC,
50/60 Hz (ST)
- 347 to 480 VAC,
50/60 Hz (HV)

PHYSICAL

Dimensions (H x W x D)

- 52 x 522 x 1,317 mm (2.2 x 20.5 x 51.9 inches)

Weight

- 11.4 kg (25 lbs)

LUMEN MAINTENANCE & DRIVER LIFETIME^{10, 11}

	25°C	50°C
L₉₀ (12k)	> 300,000	> 300,000
L₈₀ (12k)	> 300,000	> 300,000
L₇₀ (12k)	> 300,000	> 300,000
Driver Lifetime	120,000	55,000

Dimensions

Luminaire

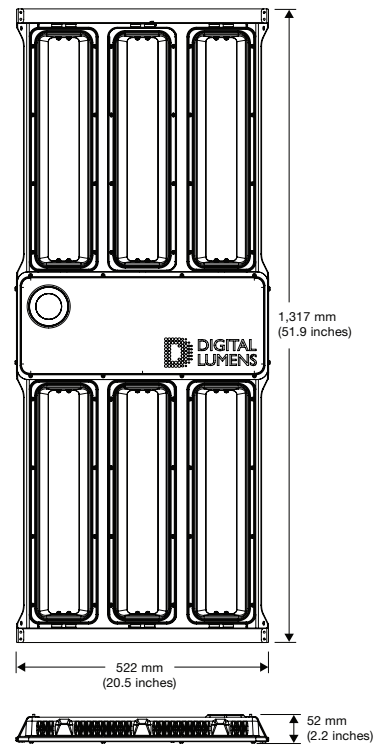

Fixed Mount Bracket

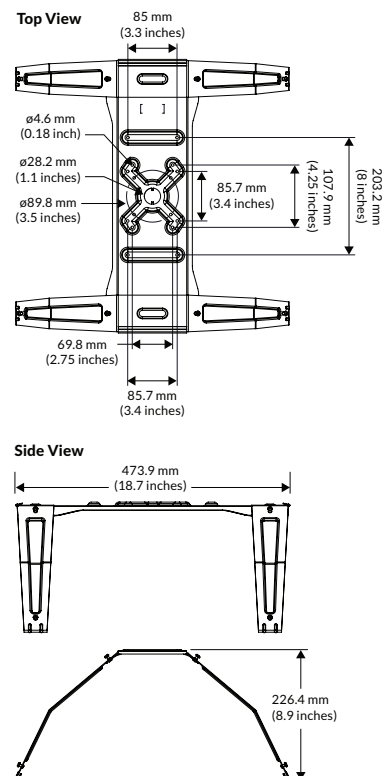

Polar Candela Distribution

Fixed Axis ----- Adjustable Axis —————

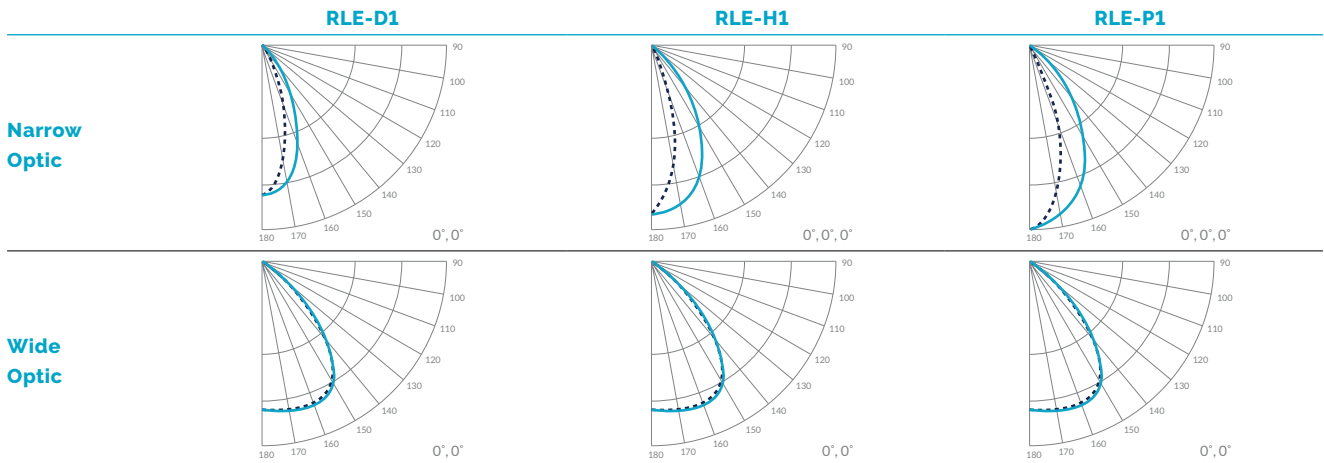

Ordering Information

For ordering information please contact sales@siteworx.io. To order your RLE Luminaires, use the table below as a guide for encoding item numbers. Select a luminaire type (lumen output), voltage, optic, and CRI/CCT, and then use the hyphenated character codes to build a part number (eg. **RLE-D1-ST-NX-751**).

Note: For short/standard lead times, select options in **bold**.

Luminaire	Type	Voltage	Optic	CRI/CCT
RLE	-D1	-ST Standard Voltage	-NX Narrow	-841 4,000 K CCT BBDRLE Compatible LGT Port
	-H1		-WX Wide	-849 4,000 K CCT BBDRLE Compatible No Sensor
	-P1	-HV High Voltage	-NG Narrow Glass	-751 5,000 K CCT BBDRLE Compatible LGT Port
			-WG Wide Glass	-759 5,000 K CCT BBDRLE Compatible No Sensor

Footnotes:

- SiteWorx Software designs with chemical resistance in mind by minimizing or eliminating the use of structural plastics and selecting, where required, chemically resistant plastics. For more information contact your SiteWorx Software representative.
- RLE-H1 and P1 units can be used for indirect lighting applications. Only the middle lightbars can be rotated in an upward fashion.
- Calculated in nominal application environment.
- 60°C maximum for RLE-P1 at 120VAC operation.
- Clean with mild soap and water only. Maintain 10 ft (3 m) setback from walls open to exterior.
- Nominal CCT, as defined by ANSI C78.377-2008.
- Wide optic.
- Efficacy values vary with optic option. See DLC QPL for variant details.
- Input ratings may vary for international certifications.
- LEDs are driven lower to enhance efficiency and increase lifetime of the LEDs. Drivers are tested at ambient 25°C (77°F), 100% continuous duty. Driver design target is always minimum > 50,000 hours at 25°C (77°F).
- LM-79, LM-80 tests and reports are performed in accordance to IESNA standards, per TM-21. Lumen maintenance projected in hours (L70 via TM-21) based on continuous operation.

Sensor Coverage

Standard Optic

Top View

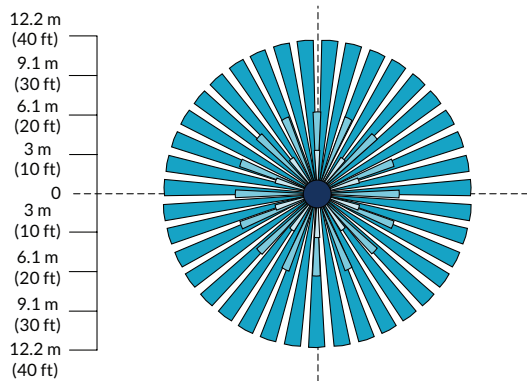

Side View

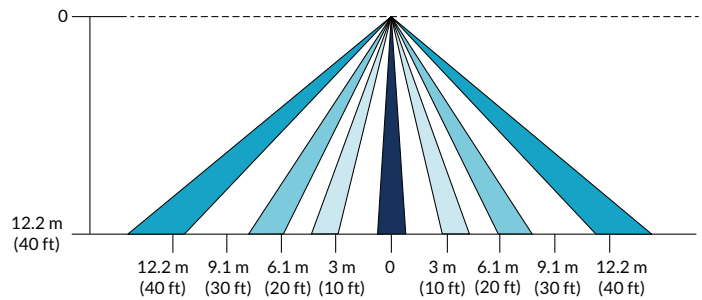

RLE Luminaires & Accessories

RLE-D1

Part Number	Lumens	Power @ 120 VAC (ST) / 347 VAC (HV)	Efficacy
RLE-D1-ST-NX-751	21,647 lm	145 W	150 lm/W
RLE-D1-ST-WX-751	21,570 lm	145 W	149 lm/W
RLE-D1-ST-NX-841	18,849 lm	144 W	131 lm/W
RLE-D1-ST-WX-841	18,740 lm	144 W	130 lm/W
RLE-D1-HV-NX-751	21,591 lm	142 W	152 lm/W
RLE-D1-HV-WX-751	21,525 lm	142 W	151 lm/W
RLE-D1-HV-NX-841	18,939 lm	141 W	134 lm/W
RLE-D1-HV-WX-841	18,829 lm	141 W	133 lm/W

RLE-H1

Part Number	Lumens	Power @ 120 VAC (ST) / 347 VAC (HV)	Efficacy
RLE-H1-ST-NX-751	32,462 lm	215 W	151 lm/W
RLE-H1-ST-WX-751	32,219 lm	214 W	150 lm/W
RLE-H1-ST-NX-841	28,247 lm	212 W	133 lm/W
RLE-H1-ST-WX-841	28,360 lm	212 W	134 lm/W
RLE-H1-HV-NX-751	32,842 lm	210 W	156 lm/W
RLE-H1-HV-WX-751	32,040 lm	210 W	152 lm/W
RLE-H1-HV-NX-841	28,784 lm	209 W	138 lm/W
RLE-H1-HV-WX-841	28,745 lm	209 W	138 lm/W

RLE Luminaires & Accessories (cont.)

RLE-P1

Part Number	Lumens	Power @ 120 VAC (ST) / 347 VAC (HV)	Efficacy
RLE-P1-ST-NX-751	64,686 lm	428 W	151 lm/W
RLE-P1-ST-WX-751	64,532 lm	428 W	151 lm/W
RLE-P1-ST-NX-841	56,546 lm	429 W	132 lm/W
RLE-P1-ST-WX-841	56,563 lm	429 W	132 lm/W
RLE-P1-HV-NX-751	64,624 lm	419 W	154 lm/W
RLE-P1-HV-WX-751	65,419 lm	419 W	156 lm/W
RLE-P1-HV-NX-841	57,391 lm	415 W	138 lm/W
RLE-P1-HV-WX-841	57,417 lm	415 W	138 lm/W

LG T Sensing and Communications Modules

Part Number	Description
PIR	PIR Module
PIR-BLE	PIR-BLE Module

Accessories

Part Number	Description
RHHRM	Fixed mount hanging hardware, compatible with RLE luminaires (5-pack)
DHHAS	Aircraft cable hanging hardware, compatible with RLE and DLE luminaires (Qty 10, for 5 luminaires)
RWUL	Pre-wired with wiring door, 10 ft (3 m) whip, 600 V, (UL) SEOOW
RWCE	Pre-wired with wiring door, 10 ft (3 m) whip, 300 V, (CE) H07RN-F

BDRLE—Battery Backup

Specifications

PERFORMANCE

Input Voltage

- 120 to 480 VAC, 100 mA @ 120 VAC

Output Voltage

- 20.5 W, 80 to 200 VDC — UL
- 10.3 W, 80 to 200 VDC — CE

ENVIRONMENTAL

Runtime

- 90 minutes — UL
- 180 minutes — CE

Operating Temperature

- 32° to 122°F (0° to 50°C) — UL
- 32° to 86°F (0° to 30°C) — CE (RLE-D1/H1)
- 32° to 77°F (0° to 25°C) — CE (RLE-P1)

PHYSICAL

Battery Type

- NiMH

Dimensions (H x W x D)

- 85.6 x 433 x 163 mm (3.4 x 17 x 6.4 inches)

Weight

- 2.3 kg (5.07 lbs)

WARRANTY

- 5-Year Limited

CERTIFICATIONS & SAFETY

Approbation

- ETL, CE, UKCA, FCC

Environmental Suitability

- Indoor Use Only, IP66



Dimensions

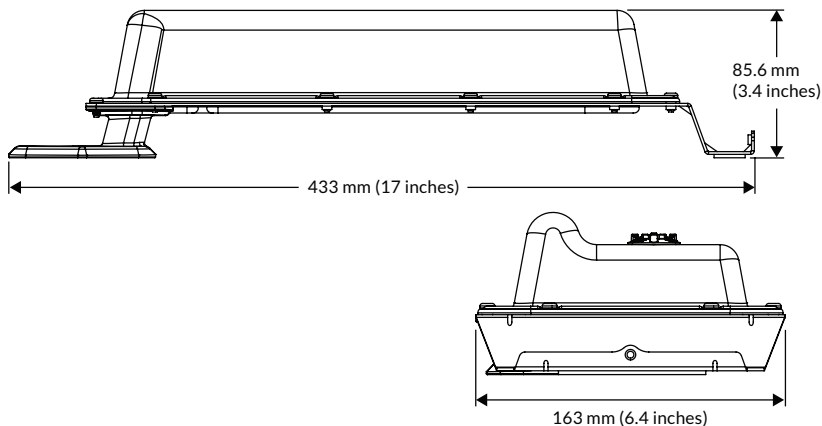

Ordering Information

- BDRLE suitable for all RLE luminaires
- Output across models approximately 3,000 lumens

Battery Backups

Part Number	Description
BDRLE-UL	Battery Backup — UL
BDRLE-CE	Battery Backup — CE

BDRLE Illumination Area

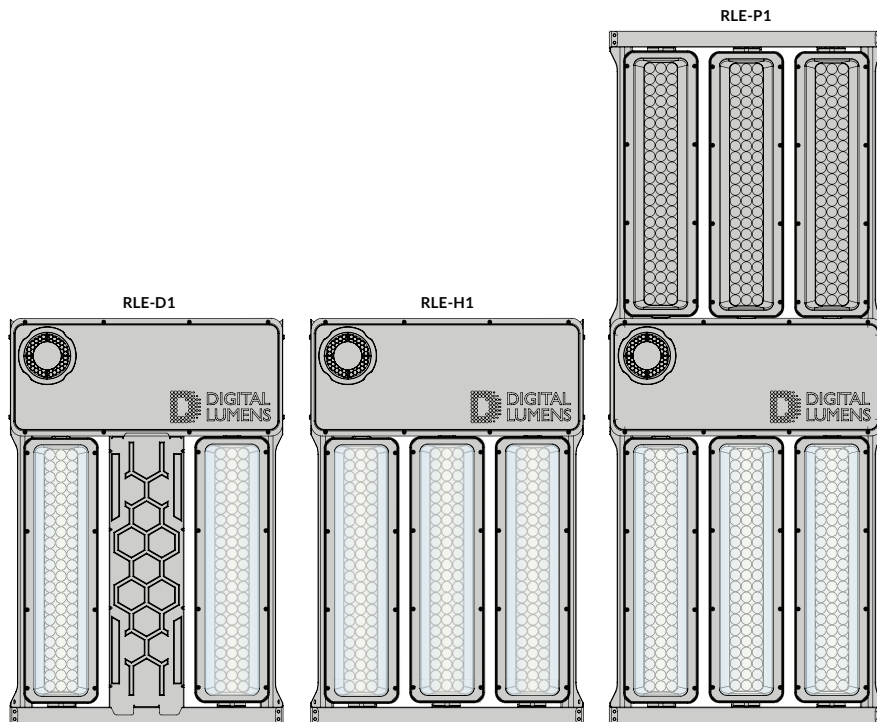

BDRLE Assembly

RLE-D1/H1

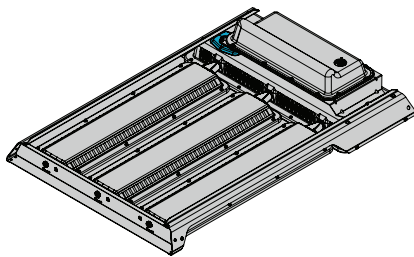

RLE-P1

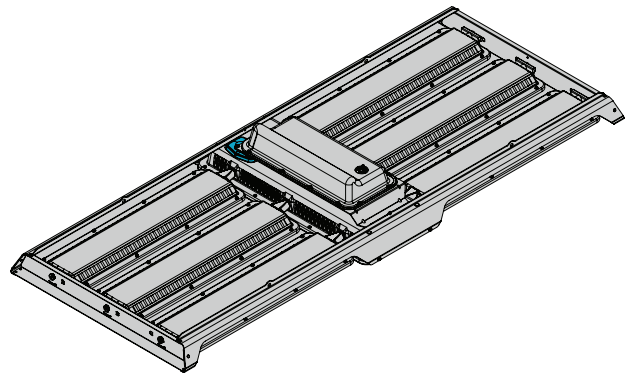

Mounting Options

Aircraft Cable

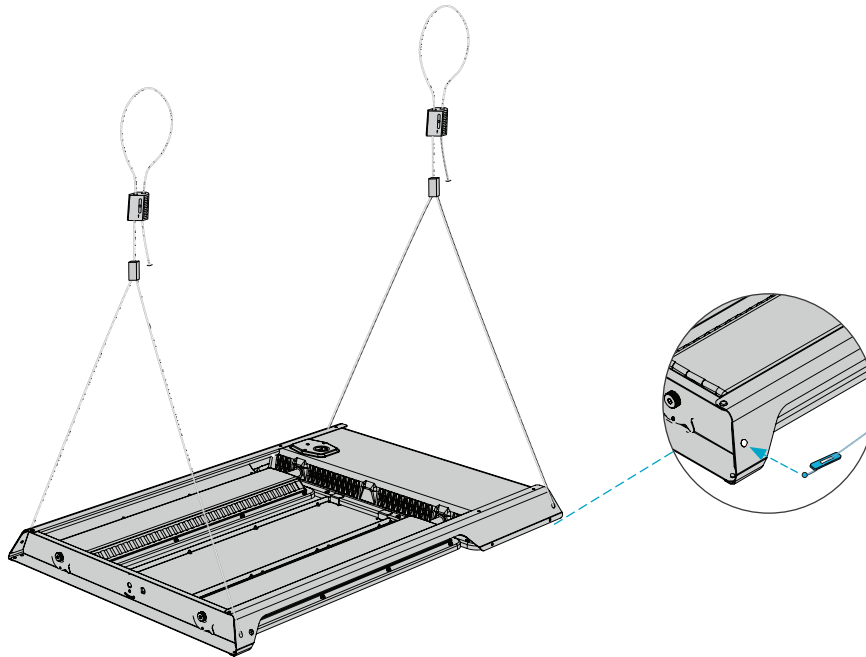

Fixed Mount

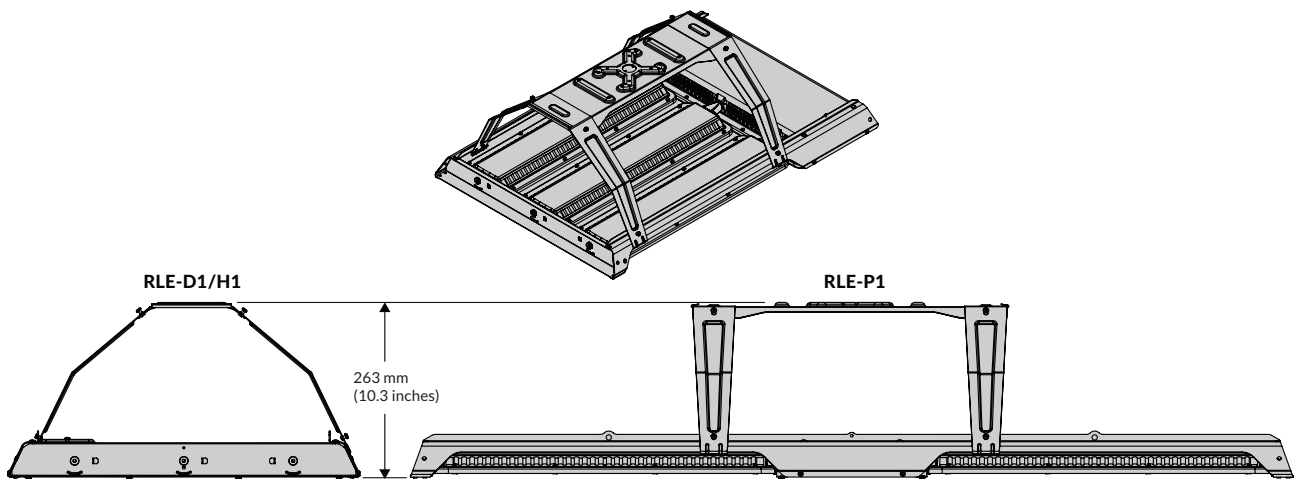

Copyright © 2024 SiteWorx Software USA, LLC.

All rights reserved. SiteWorx, the SiteWorx logo, We Generate Facility Wellness, LightRules, and any other trademark, service mark, or tradename (collectively "the Marks") are either trademarks or registered trademarks of SiteWorx Software USA, LLC in the United States and/or other countries, or remain the property of their respective owners that have granted SiteWorx Software USA, LLC the right and license to use such Marks and/or are used herein as nominative fair use. Due to continuous improvements and innovations, specifications may change without notice.

DOC-001705-00 Rev I 07-24